

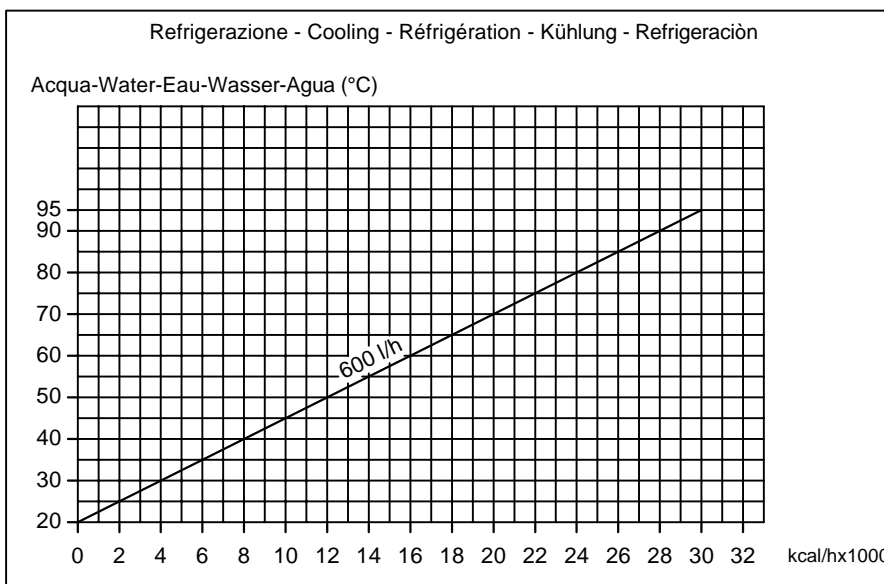

Fluido= Acqua Fluid= Water Fluide= Eau Flüssigkeit= Wasser Fluido= Agua	Potenza riscaldamento Heating power Puissance chauffage Leistung heizung Potencia calefaccion	Resistenza Resistance Resistance Widerstand Resistencia	Potenza pompa Pump power Puissance pompe Pumpenleistung Potencia bomba	Portata pompa Pump flow Débit pompe Pumpe Durchflußmenge Caudal bomba	Prevalenza pompa Pump pressure Pression pompe Pumpendruck Presión bomba	Temperatura max. Max. temperature Temperature max. Höchsttemperatur Temperatura max
	kW	n° kW	kW (ass./inst.)	l/min min. nom. max.	bar max. nom. min.	°C
	6	1x 6	0,58/0,75	16 30 100	3,3 3,2 2,4	95

Rumorosità Noise Bruit Geräusch Ruido	Capacità interna Internal capacity Capacité interieure Innerekapazität Capacidad interior	Peso a vuoto Net weight Poids net Leergewicht Peso en vacio	Dimensioni imballo Packaging dimensions Dimensions emballage Verpackungsabmessungen Dimensiones embalaje	Sistema raffreddamento= diretto Cooling system= direct Systemé de refroidissement= direct Kühlungssystem= direkt Sistema de enfriamiento= directo
dB(A)		litri	kg	mm
1m	10m			
60	40	3	60	-

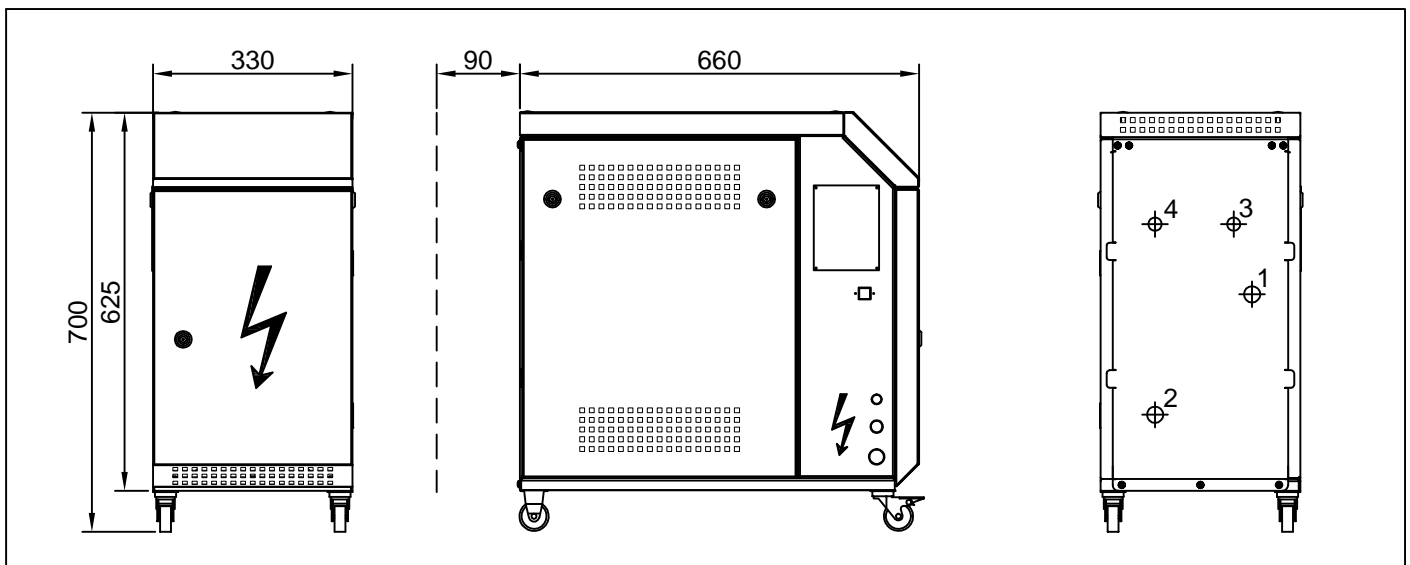

1	Mandata - Delivery - Refoulement Vorlauf - Empuje	Ø3/4"
2	Ritorno - Return - Retour - Rücklauf - Retorno	Ø3/4"
3	Entrata raffreddamen. -Cooling inlet- Entrée refroidisse. -Kühlungszufluss- Entrada refrigeracion	Ø1/2"
4	Uscita raffreddamen. -Cooling outlet- Sortie refroidisse. -Kühlungsausluss- Salida refrigeracion	Ø1/2"

Potenza elettrica totale Total electric power Puissance électrique tot. Gesamtstromstärke Potencia electrica total	ass. 6,9 kW	Corrente Max Max. Current Courant max. Max. Spannung Corriente máx.	A	Magnetotermico Magnetothermic Switch Interr. Magnétothermique Magnetothermis. Schalter Interr. Magnetotérmico	A
	inst. 7 kW		12		16

INDUSTRIAL FRIGO SI RISERVA IL DIRITTO DI MODIFICARE I DATI DELLA PRESENTE SCHEDA TECNICA IN QUALUNQUE MOMENTO.
INDUSTRIAL FRIGO RESERVES THE RIGHT TO MODIFY THE DATA OF THIS TECHNICAL CARD IN ANY TIME, WITHOUT PRIOR NOTICE.
INDUSTRIAL FRIGO SE RÉSERVE LE DROIT DE MODIFIER LE DONNÉES DE CETTE FICHE TECHNIQUE SANS PRÉAVIS.
INDUSTRIAL FRIGO BEHÄLT SICH DAS RECHT VOR, DIE VORLIEGENDE DATEN OHNE VORHERIGE BENACHRICHTIGUNG ZU ÄNDERN
INDUSTRIAL FRIGO SE RESERVA EL DERECHO DE MODIFICAR LOS DATOS DE ESTA FICHA TECNICA UN QUALQUIER MOMENTO.

380/400/415V - 3 - 50Hz	
08.09.20	P680064.02